

## S4 单刀剪线/Single Knife Thread Trimmer

## S4-DC 双刀剪线/Double Knife Thread Trimmer

自动步进电脑平缝机

Automatic Stepping Motor Controlled S/N Lockstitch Machine



全新设计的智能化的产品，具有一体型电控、内嵌式大屏亚克力操作面板，单步进电机控制针距、倒缝、剪线、抬压脚、松线功能，标准USB接口等多种功能。广泛适用于各种衬衫、西服、裤子的缝制。

The newly designed intelligent product has integrated electronic control, built-in large-screen acrylic operation panel, single-step motor control stitch distance, reverse sewing, thread trimming, presser foot lift, standard USB interface and other functions.



集成内嵌式的大屏操作面板，发光LOGO  
Integrated built-in large-screen operation panel, illuminated LOGO

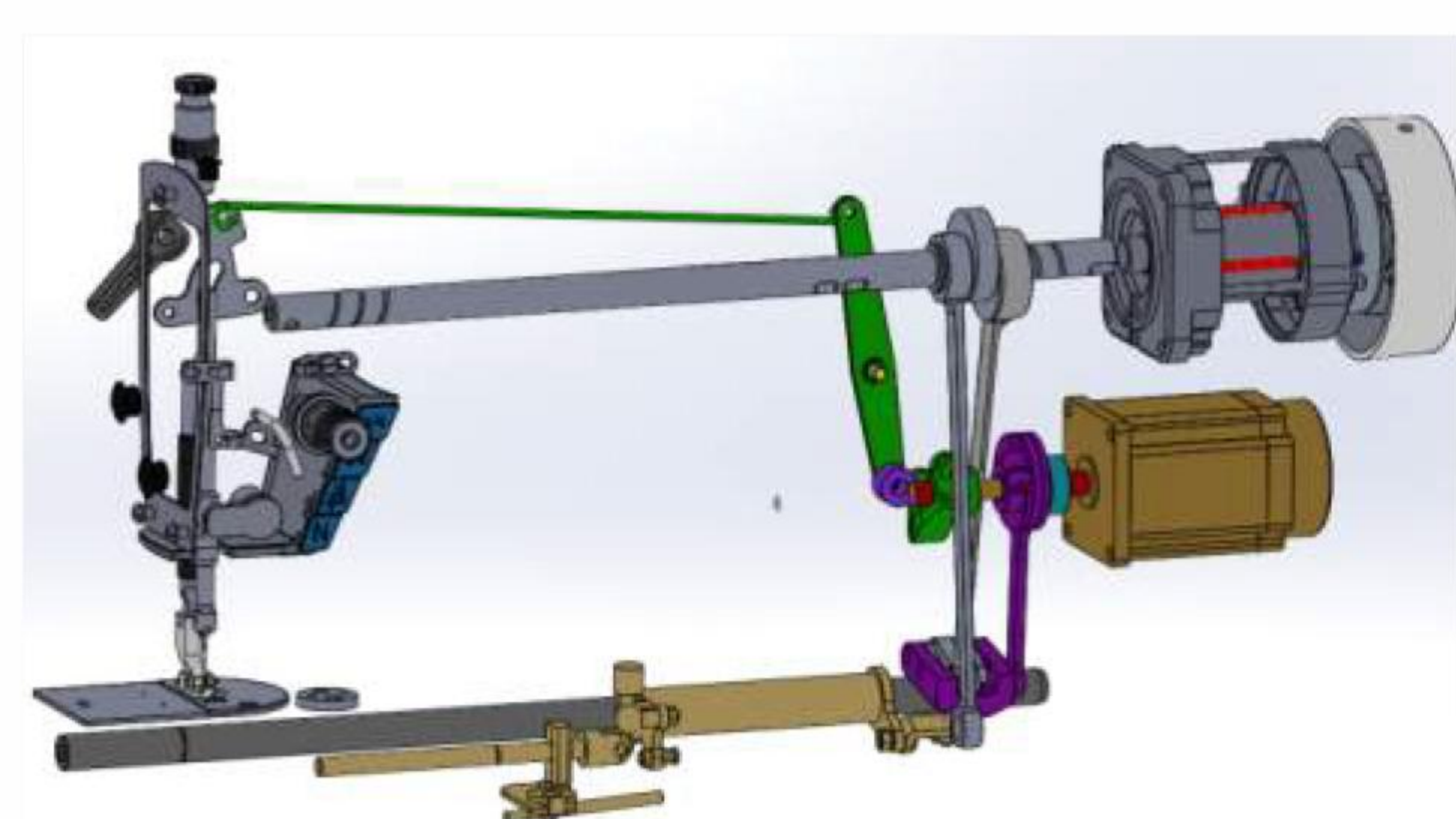

步进电机一拖四控制：针距、倒缝、剪线、抬压脚、松线  
Step motor control 4 automatic functions: Needle gauge, reverse feeding, trimming, pressure foot lift.



四键开关LED灯，增加1/4、1/2补针功能  
Four-key switch LED light, add 1/4, 1/2 needle filling function



大风力手轮加大进气量，降低电机电控温度，提高使用寿命  
High efficiency hand wheel, with better air ventilation: reduce the temperature of the motor and control box.

	S4	S4-DC	S4-H	S4-B	mm	mm	mm	mm	s.p.m	★	—	550	mm x mm x mm	kg
	★	—	★	★	5	5.5/13	30.7	DBX1#14	5000	★	—	550	700X270X560	35.5/42.5
	★	—	★	★	5	5.5/13	30.7	DBX1#14	5000	★	—	550	700X270X560	35.5/42.5
	—	★	★	★	7	6/13	35	DPX5#18	4500	★	—	550	700X270X560	35.5/42.5
	—	★	★	★	7	6/13	35	DPX5#18	4500	—	★	550	700X270X560	35.5/42.5

注：标配为沪龙电控、步进电机、国产旋梭、自动剪线、自动倒回缝、自动抬压脚、电子夹线、电子松线功能。标配封闭式油盘，可选配开放式油盘。

Note: The standard configuration is Hulong electronic control, stepper motor, domestic rotary hook, automatic thread trimmer, automatic reverse sewing, automatic presser foot lift, and electronic thread clamp, electronic wire release function. A closed oil pan is standard, and an open oil pan is optional.

Contact